

MILCOM

SURFACE STATION USER MANUAL

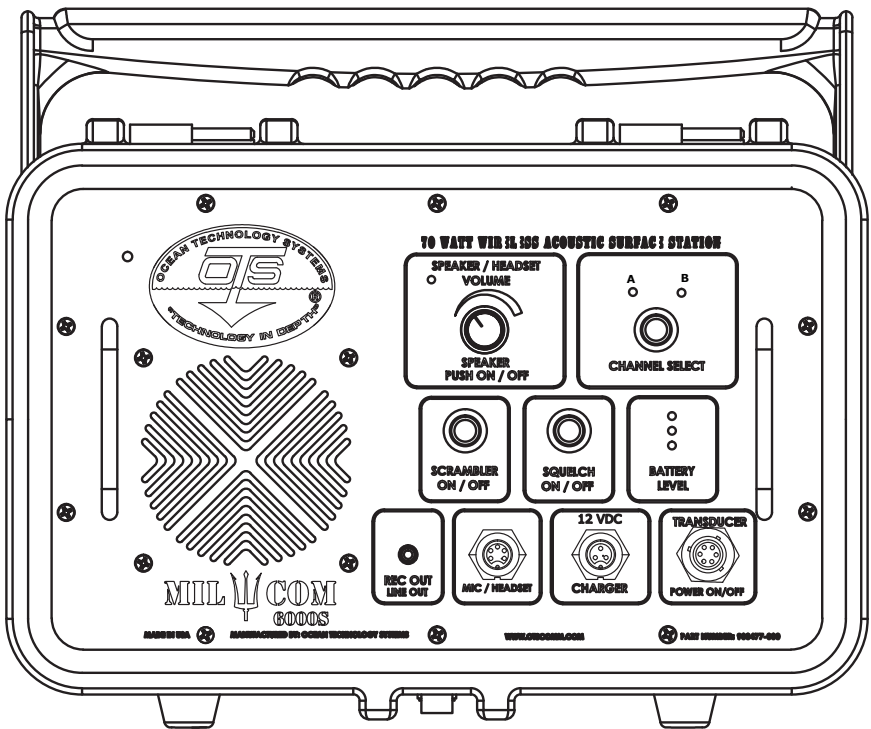

OCEAN TECHNOLOGY SYSTEMS

- NOTICE -

All users are instructed to read and fully understand the MilCom Surface Station 6000S manual before using. This manual and the information contained herein are provided for use as a maintenance and operation guide. No license or rights to manufacture, produce, and/or sell either the manual or articles described herein are given. Undersea Systems International, Inc., dba Ocean Technology Systems hereinafter referred to as OTS, reserves the right to change specifications without notice.

All statements, technical information, and recommendations herein are based on tests we believe to be reliable, but the accuracy or completeness thereof is not guaranteed; and the following is made in lieu of all warranties, expressed or implied, including the implied warranties of merchantability and fitness for purpose: Seller's and Manufacturer's only obligation shall be to replace such quantity of the product proved to be defective. Before using, the user shall determine the suitability of the product for intended use, and the user assumes all risk and liability whatsoever in connection therewith. Neither Seller nor Manufacturer shall be liable either in tort or in contract for any loss or damage—direct, incidental, or consequential—arising from the use of or the inability to use the product. No statement or recommendation not contained herein shall have any force or effect unless it is in an agreement signed by officers of the Seller and Manufacturer.

- IMPORTANT SAFETY NOTICE - ***(Please read before using product)***

It is absolutely essential that all divers are certified, in good standing, properly trained, equipped, and fully understand this user's manual before attempting to use the MilCom Surface Station 6000S. While the MilCom Surface Station 6000S does provide the diver with the ability to communicate underwater, it does not change or eliminate the potential hazards of diving.

Refer to the User Manuals page of our Website at:

www.oceantechnologysystems.com for a list of any changes made to this manual since its publication.

Any defect of the product in workmanship or material discovered within one year from the date of purchase must be promptly communicated in writing to Ocean Technology Systems.

Ocean Technology Systems



3133 West Harvard St., Santa Ana, CA 92704 USA

Telephone: 714.754.7848 Fax: 714.966.1639

E-Mail: ots@otscomm.com

Web: www.otscomm.com

WARNING SYMBOLS

Caution: 	Minor or moderate injury could occur.
Warning: 	Serious Injury or death could occur.
Danger: 	Imminently hazardous causing injury or death.

BATTERY DISPOSAL WARNING



Dispose of the Lithium-Ion battery and the Battery Charger in accordance with the local, state, and federal electronic waste recycling regulations. Do not discard them in the trash.

BATTERY WARNINGS

MilCom Surface Station 6000S contains Lithium-Ion battery pack. Proper handling should always be taken to ensure the battery will operate at its optimum level. Mishandling or misuse of the battery could potentially affect the performance and Safety of the battery.

CAUTION

- Please read the manual before charging.
- Lithium-Ion batteries have a predefined number of charge cycles, if the batteries won't hold the charge or requires more frequent charging, the battery may need to be replaced.
- Battery contains a protection circuit to prevent damage to the battery during use. Care must be taken to ensure the battery is not damaged.
- If the battery will not take a charge (LED on the charger does not switch from Green to Red when connected to a unit with depleted battery)
- Discontinue charging. Please contact OTS for further instructions.
- If the battery is not fully charged after 12.5 hours, discontinue charging. Please contact OTS for further instructions.
- Battery must be charged at a temperature range between 0°C (32°F) and 45°C (113°F). Battery operation should be between -10°C (14°F) and 60°C (140°F).
- The battery must be stored away from children and pets.
- If the battery is completely drained, charging will be necessary to maintain the health of the battery. Do not leave a completely discharged battery in storage for a long period without charging. (Greater than 6 months)



 **DANGER**



The Milcom Surface Station 6000S uses Lithium-Ion rechargeable batteries which can explode or cause fire if damaged or stored incorrectly.

IF STORED INCORRECTLY OR DAMAGED

Read and follow the Battery Warnings, Cautions and Prohibitions below before using.

Failure to adhere to these guidelines could result in serious injury or death caused by fire or explosion.



DANGER

Failure to adhere to these guidelines could result in serious injury or death.

- Do not place the battery in direct sunlight or in direct contact with a heat source.
- Do not use the battery in high static environment where the battery can be damaged due to static electricity.
- When storing two or more individual batteries in the same location, ensure the battery contacts are protected from coming into contact with another battery.
- Do not use this battery for other applications.
- Do not allow any conductive materials to come in contact with the battery terminals.
- Only use the battery charger provided by OTS to charge the battery. An unapproved charger could result in an over charge state and potentially damage the battery. Using an unapproved charger will void your warranty.
- If the battery contacts are corroded or if the battery emits an unusual odor, please contact OTS.
- Do not disassemble or reconstruct the battery.
- Do not throw, drop, or cause impact to the battery.
- Do not pierce a hole or puncture the battery with sharp objects.
- Do not use any other batteries or cells in this unit.
- Do not apply solder on the battery.
- Do not expose the battery to high temperature greater than 60°C (140°F).
- Do not put the battery into a microwave or high-pressure container.
- Do not connect positive (+) and negative (-) contacts with any conductive materials (such as metal or wire).
- Do not allow the battery to get wet or immerse in water.
- If you suspect that water has breached the unit, do not open the unit if the unit is hot to the touch. Move unit away from any structures and vehicles. Place it in a safe area. Let the unit cool completely before handling. Contact OTS.

TABLE OF CONTENTS

NOTICE	I
WARNING SYMBOLS.....	II
BATTERY DISPOSAL.....	II
BATTERY WARNING	III
CAUTION	III
INTRODUCTION.....	1
GENERAL.....	1
SPECIFICATIONS	2
ANATOMY OF THE SURFACE STATION	3
GETTING STARTED.....	6
MAKING ADJUSTMENTS.....	8
MAINTENANCE.....	11
MAINTENANCE INTERVALS	11
PRE-DIVE CHECKLIST FOR ESTABLISHING	11
COMMUNICATIONS.....	11
POST DIVE PROCEDURE.....	11
REPLACEMENT / SPARE PARTS	12
REPLACEMENT PART INSTRUCTIONS.....	13
TROUBLESHOOTING GUIDE	19
UNDERSTANDING WIRELESS UNDERWATER COMMUNICATIONS	20
LIMITED WARRANTY.....	26

INTRODUCTION

Congratulations on purchasing one of the most advanced and powerful underwater communications available. The MilCom Surface Station 6000S wireless communication system mark a significant advancement in technology and power, providing unsurpassed voice communications to any professional dive operation. MilCom Surface Station 6000S systems are single-sideband (SSB) ultrasonic transceivers for diver to surface wireless communications.

This advanced system have our newest feature, scrambler mode for more secure communications to our other wireless communication units. MilCom Surface Station 6000S systems are backward compatible to our other wireless communication units.

GENERAL

This manual contains information regarding the details, operation, care and maintenance of the MilCom 6000S underwater communication system including ear-phone/microphone assemblies and support equipment (not included).

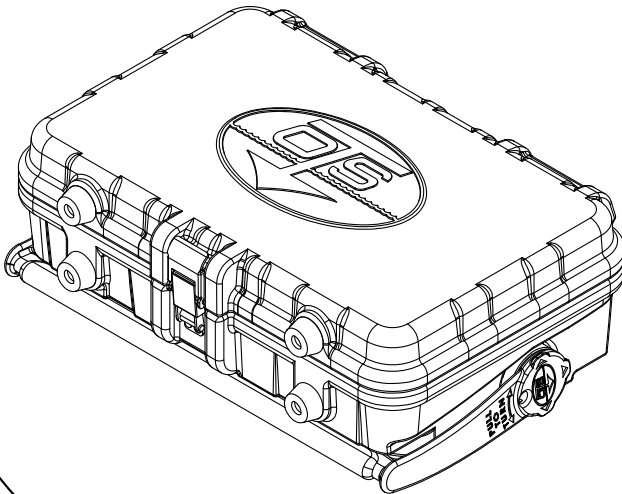

SPECIFICATIONS

Nominal Range: Calm Sea: up to 6000 m (feet)
 Sea State 6: up to 200 m (Feet)

Many factors can affect the range of the unit see section, Understanding Wireless Underwater Communications beginning on page 20 for more information.

Acoustic Output Power: 70 W Peak Envelope Power (PEP)

Audio Frequency
Response 300 Hz – 3.6 kHz

Receiver Sensitivity: –110 dBV

Automatic Gain Control: 120 dB dynamic range

Transmitter Activation: Manual activation Push-To-Talk (PTT)

Transmitter Band: 28.5–33 kHz 2 channel

Battery Type: 2 Lithium-Ion Battery Packs

Battery Life: 26 hours (10% duty cycle)

Housing: Polyethylene

Unit Dimensions: 14 in x10 in x 5.5 in (356 mm x 254 mm x 140 mm)

Unit Weight: 9.8 Pounds (4.4 Kg)

Operating Temperature: 0°C to 60°C (32°F to 140°F)

Storage Temperature: –20°C to 45°C (–4°F to 113°F)

Battery Status Indicator: Green, Yellow, Red LED, and Audio Indicator

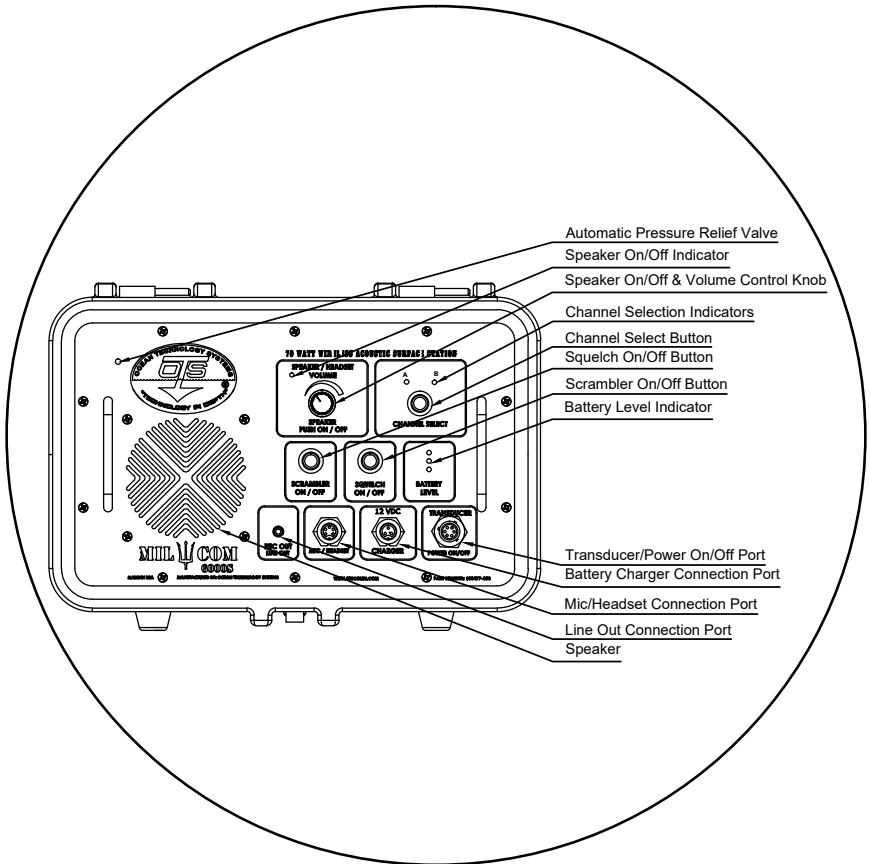

AUTOMATIC INTERNAL PRESSURE RELIEF PORT

The Automatic Internal Pressure Relief Port allows for pressure equalization between the inside of the unit and the outside of the unit.

SPEAKER ON / OFF INDICATOR

The speaker On / Off indicator will illuminate when the speaker is on and will be dark when the speaker is off.

SPEAKER ON / OFF & VOLUME CONTROL KNOB

The Speaker On / Off & Volume Control Knob allows you to turn the speaker on and off and adjust the volume level of sound output from the unit. The Speaker can be turned off for use with a headset to isolate communications with the tender. Press down on the knob to switch the Speaker On / Off. When the unit is powered on by default the speaker is on. Turn the knob clockwise to increase the volume, counter clockwise to decrease.

CHANNEL INDICATORS

The Channel Indicators will illuminate to display the channel that has been selected by the Channel Select Button.

CHANNEL SELECT BUTTON

The Channel Select Button allows you to change the transmit and receive frequency of the unit.

SQUELCH ON / OFF BUTTON

The Squelch On / Off Button allows you to switch the squelch functionality either on or off. The LED circle around the button will illuminate when the squelch is on and will be dark when the squelch is off.

SCRAMBLER ON/OFF BUTTON

The Scrambler On / Off Button allows you to switch the scrambler functionality either on or off. The LED circle around the button will illuminate when the scrambler is on and will be dark when the scrambler is off.

BATTERY LEVEL INDICATORS

The battery level indicators display how much charge remains in the unit. See section, Battery Level Indicators on page 10 for more information.

TRANSDUCER / POWER ON / OFF PORT

The Transducer / Power On / Off Port is where the user connects the transducer cable to the unit. Connecting the transducer to this port will power the unit on and removing the transducer will power the unit off.

BATTERY CHARGER CONNECTION AND EXTERNAL POWER PORT

The Battery Charger Connection Port is where the user connects the battery charger to the unit. Connect the included battery charger to the unit to charge the unit's battery. 12V DC External power can be connected to the Battery Charger Connection Port to power the unit without relying on the batteries. See section, Using 12V External Power on page 10 for more information.

MIC/HEADSET CONNECTION PORT

The Mic/Headset Connection Port will allow the user to connect either the included Hand-Held Microphone or an optional THB-PMC headset with boom microphone. Either will work while connected to the unit.

LINE OUT CONNECTION PORT

The Line Out Connection Port is a female RCA 3.5 mm jack that will allow the user to connect external recording devices or external speakers to the unit. The audio output is Line Level. NOTE: Do not connect phantom power to the jack, doing so can damage the unit.

SPEAKER

The Heavy Duty front panel speaker allows for clear and loud audio.

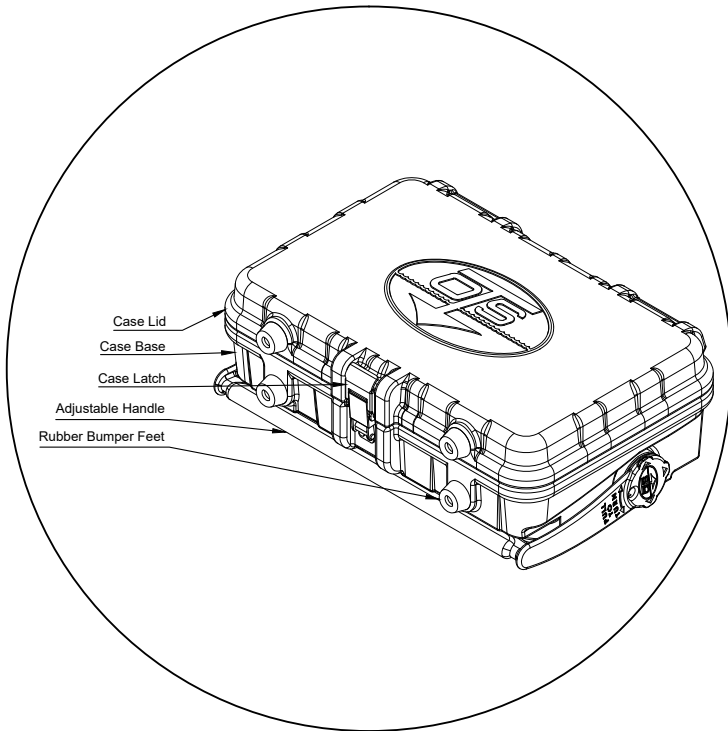

CASE LID

The Case Lid protects the unit from damage during storage or transport. The Case Lid is removable for normal usage.

CASE BASE

The Case Base protects all major components from transport, storage and water damage.

CASE LATCH

The Case Latch secures the lid to the case base for transport and storage.

ADJUSTABLE HANDLE

The Adjustable Handle functions both as the carrying handle for the unit and as the “Kick Stand” for the unit. This allows you to place the unit at any of three use-angles see Section, Getting Started for more information about the use angles. The Adjustable Handle is user replaceable if it gets damaged.

RUBBER BUMPER FEET

The rubber bumper feet provide stability to the unit during use, transport or storage.

GETTING STARTED

Unlatch the unit and open the top lid. You may remove the lid or keep it attached per your personal preference. Next, adjust the handle to support the unit for whichever unit position works best for your application. To adjust the handle grasp the ends and slightly pull away from the unit to disengage the locking mechanism. While still pulling the handle apart, rotate the handle away from the unit. The handle adjusts to three positions.

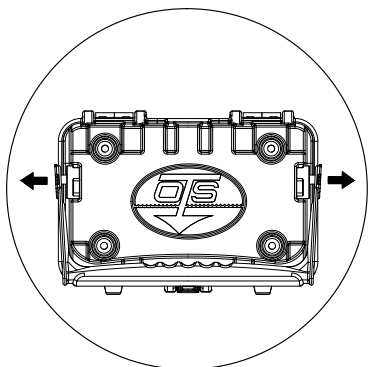

Pull Apart

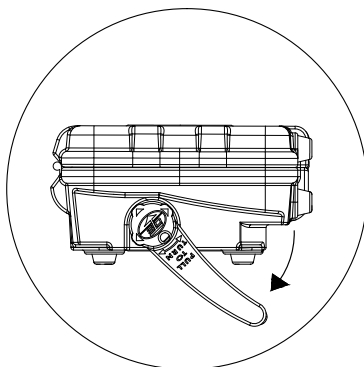

Rotate Handle

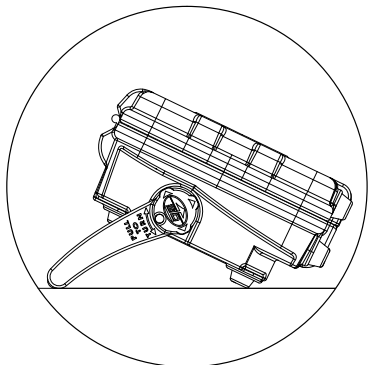

Handle In Position 1
(Approximately 60°)

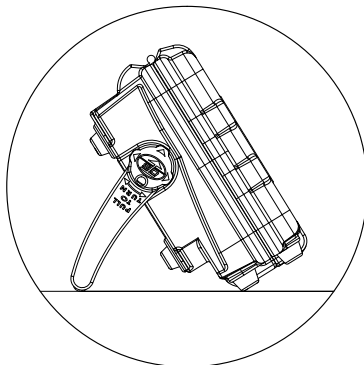

Handle In Position 2
(Approximately 120°)

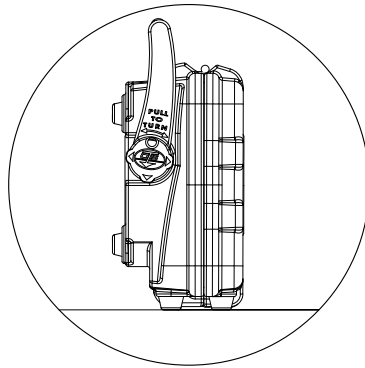

Handle In Position 3
(Approximately 180°)

To power the unit on, mate up the connector of the transducer cable to the Transducer / Power On / Off Port on the panel, rotate the cable connector gently until it indexes and lock into place with the cable's locking ring. The unit's LEDs will illuminate and a voice will read out the current settings. On first startup, these settings will be the factory default settings.

If you cannot hear the speaker reading out the current settings, ensure that the Speaker On / Off indicator is lit and that the Speaker volume knob is not turned completely counter-clockwise. If the Speaker On / Off indicator is not lit, depress the speaker knob to activate the speaker, then turn the Speaker volume knob clockwise, increasing until volume can be heard from the unit. The volume knob can be turned counter-clockwise to decrease volume and turned clockwise to increase volume at any time.

Once the unit is powered on, the speaker is on, and the volume is turned up, you are almost ready to transmit. To complete the setup process, connect the provided Hand-Held Microphone (HHM-5) to the unit. An optional THB-PMC Headset can also be connected in place of the handheld microphone. Keying the push-to-talk button on the microphone and speaking into it will transmit a voice signal through the transducer. The unit can be tested through air before the divers enter the water by holding the transducer within six feet of the diver's transceivers.

For normal operation ensure that the transducer is submerged in water. Transducer depth should be adjusted based on your dive conditions. See understanding wireless underwater communications on page 20 for more information about transducer placement.

NOTICE: Transducer cable should be secured to the boat to prevent cable from pulling the radio. Ensure transducer will not get pulled into boat propeller.

You are now ready to communicate. The default system settings are optimized for everyday use of the unit. You can change any options you wish to suit your mission profile. Such options include: Squelch On / Off, Scrambler On / Off, Speaker On / Off, volume level adjustment, and channel select.

MAKING ADJUSTMENTS

The following instructions will explain how and why to change your options and settings of the MilCom Surface Station. The table below lists the factory default options. The unit will remember Channel and Scrambler settings between uses, but will default to Speaker on and Squelch On when powered on.

Option	Default setting
Channel	B
Speaker	On
Squelch	On
Scrambler	Off

SQUELCH

To activate our software driven, automatic Squelch simply press the button labeled Squelch. When the Squelch is on the LED ring around the button will illuminate. Squelch will default to on when unit is powered up. The Squelch option is designed to help eliminate background noise. There are a lot of noises in the spectrum used for Wireless Communications such as Marine biological noise, Mechanical noise etc. Noise can come from numerous sources such as boat engines, compressors, generators, jet skis, shrimp and even rain can affect wireless communications. Anything that produces sound can be heard though the MilCom Surface Station 6000S if the signal is in the ultrasonic frequency.

Think of Squelch as a gate that allows only the strong signal of other divers or the surface station through to your Earphone/ Microphone Assembly. If the water is particularly “noisy” you may want to turn the Squelch on. Note that when turned on, you may be limiting a weak signal from a diver or surface station if they are “shadowed” by a physical obstruction or merely distant, effectively limiting the range. If the water is particularly quiet and/or you need to hear a potentially weak signal from a distant diver/surface station, then you may want to turn the Squelch off.



Correct Squelch settings are vital to maintaining communications to divers.

SCRAMBLER

To switch in and out of Scrambler mode, press the scrambler button. Scrambler will default to off when the unit is powered on. If the scrambler is on, the LED ring around the button will illuminate. Scrambling enables divers to have more secure communication while the option is on. Divers with this feature enabled on their MilCom Surface Station diver communication units will be able to hear unscrambled speech, while divers without this feature enabled will hear unintelligible transmissions, providing an additional layer of secure voice communications. Scrambler setting is saved when unit is powered down and will remain the same when unit is powered on.

SPEAKER

To turn the speaker on or off, press down on the volume knob. When the speaker is on the speaker indicator will illuminate.



When in the off position, the unit will not have any volume coming from the unit.

If the optional headset is connected, audio from the headset can be heard even if the unit speaker is set to off. Speaker will default to on when unit is initially powered on.

VOLUME

To adjust the volume of the unit, simply turn the volume knob to the desired volume level. Turn the knob counter-clockwise to decrease the volume level. Turn the knob clockwise to increase the volume level. This will adjust the volume levels of the optional headset in addition to the volume level of the speaker.

CHANNEL

To change the unit's frequency, depress the Channel button. This will advance the channel selection number by one. (From one to two, two to three, and so forth). As you press and release the button, a voice prompt will confirm your selection in addition to the LED light illuminating along the numerical track. If you are attempting to adjust past multiple channels at once, you can press and hold the button. While holding the button, the LEDs will show the unit switching channels, again following the numerical track. When the LED signifies the desired selection, release the button. A voice prompt will confirm the choice, ensuring that you've selected the correct channel. Channel setting is saved when unit is powered down and will remain the same when unit is powered on.

Custom frequencies are available.

Contact OTS sales for details at salesupport@oceantechnologysystems.com

Channel Number	Frequency
Channel A *	28.500kHz Lower Sideband
Channel B **	32.768kHz Upper Sideband

* Maximum effective power output

** Matches Buddy Phone Channel A

The MilCom Surface Station is equipped with a high-capacity rechargeable Lithium-Ion battery that is charged through the Charger connector located along the bottom row of connectors. To charge the unit, connect the provided smart charging device.

The LED on the Battery Charger will illuminate red, indicating that charging is in progress. When the battery is fully charged, the LED on the battery charger will illuminate green to show that the battery is finished charging. Battery will take about 12.5 hours to fully charge.

BATTERY LEVEL INDICATORS

The three LED battery level indicators will indicate approximately how much charge is left in the battery. A Green light indicates the unit is charged and ready for use. A Yellow light indicates that the battery is between 40% and 10% of full charge, consider connecting external power to the unit if available, or the unit should be charged before use. A Red light indicates that the battery is less than 10% of full charge, any divers in the water should be recalled if communication is critical. When the battery level is Red, a voice prompt will also inform you that battery level is low by saying "Low Battery". When the battery is critically depleted the Red LED will blink and a voice prompt will say "Unit will shut down soon". When the battery is fully depleted, a voice will say "Unit shutting down" and the unit will shut down within 30 seconds. The amount of time that the battery will remain in any one state (Green, Yellow, Red, Blinking Red) will vary and depends on many factors including duty cycle, temperature, age, etc.

USING 12V EXTERNAL POWER

External Power can be connected to the unit, which will allow the unit to run with fully depleted batteries. Connect the provided External Power Cable Assembly (EPP-3) to a 12 VDC 10-amp power supply. Connecting the power supply in this way will bypass the batteries entirely. Using this connector will not charge unit or deplete the battery.



Some unregulated power supplies may cause noise. The included charger is not an appropriate external power supply as it will cause the unit to shut down when connected.

BATTERY DISPOSAL

Dispose of the Lithium-Ion battery and the Battery Charger in accordance with the local, state, and federal electronic waste recycling regulations. Do not discard them in the trash.

MAINTENANCE

Routine maintenance of the MilCom Surface Station 6000S units is necessary to ensure an extended life of the equipment. Failure to properly care for and maintain the MilCom Surface Station 6000S and ancillary components could lead to flooding of the units, damage to the connectors, transducers, housings and other failures. If any of this equipment is found to not be functioning as described in this manual, contact the Ocean Technology Systems service department or authorized retailer.

MAINTENANCE INTERVALS

Part	Cycle
Battery	2 years or 300 Charge cycles
Housing Lid and Base O-ring	2 years
Cable	As Required
Transducer	As Required

PRE-DIVE CHECKLIST FOR ESTABLISHING COMMUNICATIONS

1. Fully charged battery.
2. Ensure everyone is on the same Channel.
3. Perform visual inspection.
4. Are Panel screws fully tightened?
5. Are Connectors and pressure relief valve free from debris and salt?
6. Is the unit on a secure / level surface?
7. Confirm Transducer Cable assembly is secured to a cleat or similar, is free from boat props, obstructions, and is not dragging or resting on the bottom
8. In-water surface check:
 - a. Divers should recheck the location of the earphones.
 - b. Establish communication with divers and/or surface station.

POST DIVE PROCEDURE

1. Dry the unit and rinse down the transducer with fresh, clean water.
2. Wipe the panel with a damp cloth as necessary to remove salts, dirt and debris. Ensure pressure relief valve is free from salts, dirt and debris.
3. Ensure panel and controls are dry before closing case.
4. Dry all components and store in a dry, safe area.
5. Similar maintenance should be performed on all ancillary equipment.

REPLACEMENT / SPARE PARTS

Replacement / Spare part	Part Number for ordering
THB-PMC Headset	900479-000
HHM-5 Hand-Held Microphone	910514-000
RCLi-2 Battery Charger	910510-000
RBLi-8 Battery (2 Required)	900481-002
PMC Volume Knob and Cap	900481-003
PMC Panel Screws and nylon washers	900481-004
PMC Battery Bracket Assembly	900481-005
PMC Battery Blank	900481-006
Transducer TA-6	900474-004
TCA-PMC Transducer Cage	900481-007
TCA-MC-55 Cable	900481-009
TCA-6MC-55 Transducer Cable Assembly	910513-000
EPP-3 External Power Cable	912167-000
Backpack	900481-014
PMC Lid Assembly	900481-015
PMC Case Assembly with O-rings	900481-016
PMC Handle Assembly	900481-017
Foam Dividers for Backpack	900481-018
PMC Case O-rings	900481-019
Wireless Communication Patch	900481-020
OTS Patch	900481-021
PC White Board	900481-022

NOTICE: For all replacement parts, do not use a power drill or power driver. Doing so will damage the unit.

Do not tighten screws over 6 inch-pounds (0.6 newton-meters)

VOLUME KNOB

1. Firmly grab hold of the volume knob and pull it away from the panel. It will come loose with some force.

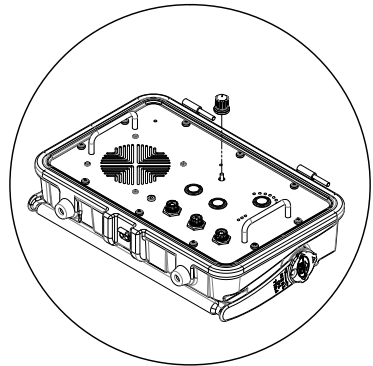

2. Push the new replacement knob into place. The knob and spindle are keyed to each other, so the knob will only go on one way. Once you've lined up the knob and spindle, press firmly to fully seat the knob.

O-RINGS

1. Remove the panel screws and nylon washers.

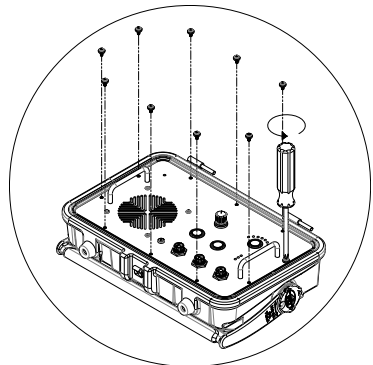

2. Remove the panel by lifting it from the panel handles.

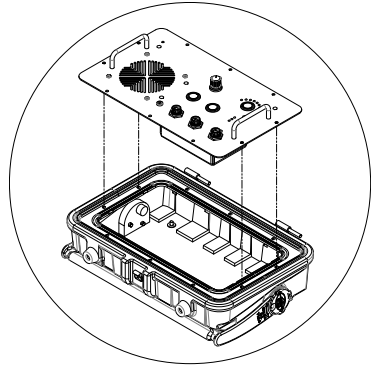

3. Using a dull plastic tool, carefully remove the O-Ring located in the O-ring groove under the panel.

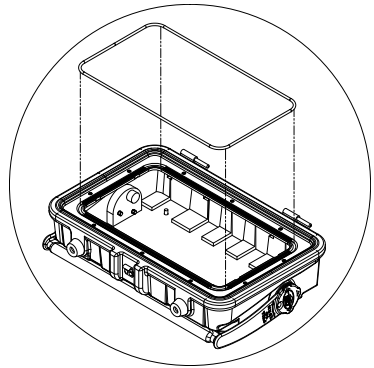

4. Replace the O-ring with the new undamaged part.

5. Place the panel back into the case and retighten the ten panel screws and nylon washers.

BATTERY BRACKET & BATTERY

1. Remove all ten panel screws and Nylon washers and set aside.

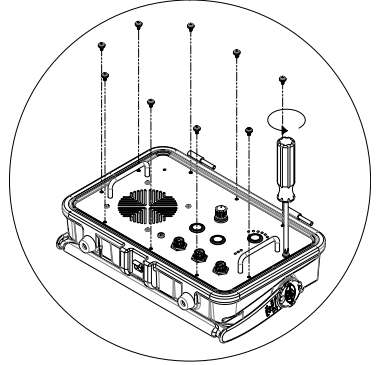

2. Lift the panel out of the case assembly and place it face-down on a clear work table.

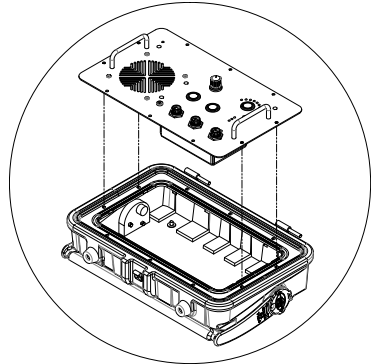

3. Using a Philips head screw driver, remove the four screws that secure the battery bracket to the panel assembly.

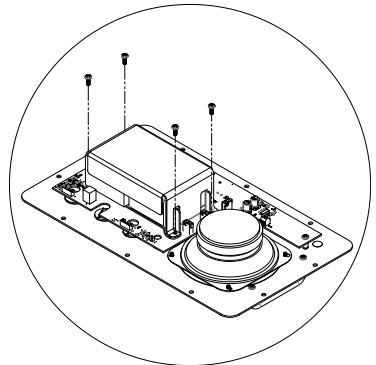

4. Lift the battery bracket from the unit, taking care not to damage the PCB.

5. Disconnect the battery from the PCB and remove the battery from the battery bracket.

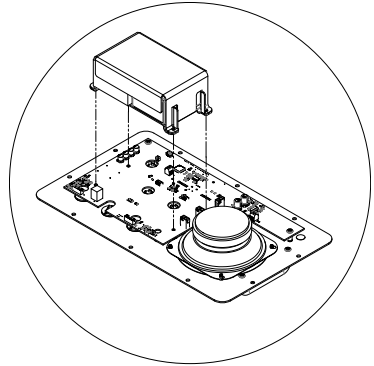

6. Place the battery into the replacement battery bracket. Place the battery bracket onto the panel assembly, lining the bracket mounting holes with the mounting holes of the PCB.

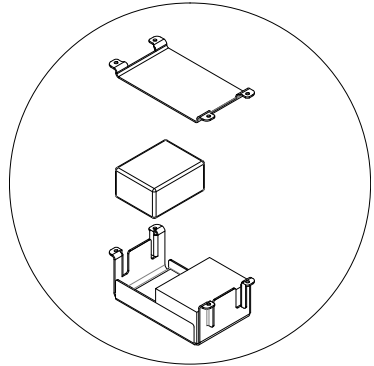

7. Using a Philips head screw driver, Replace the four battery bracket screws.

8. Flip the panel assembly back over and place it back into the case assembly. Replace the ten panel screws to secure the Panel to the case.

NOTICE: Tighten the screws tightly, otherwise the O-rings will not prevent water from intruding into the unit.

TRANSDUCER CAGE

1. Remove the four screws and pull the plastic cage a part. Replace the plastic cage and the four screws.

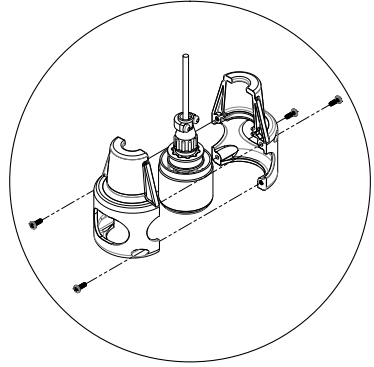

TRANSDUCERS

1. Disassemble the Transducer cage by loosening the four screws. Set the two halves of the cage aside.

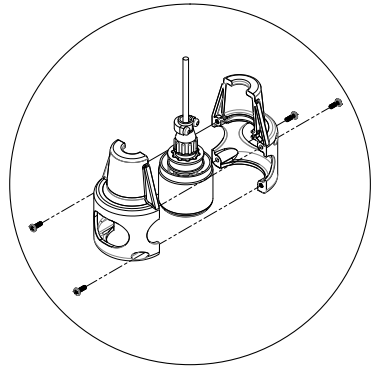

2. Rotate the locking ring on the connector. The Transducer will disengage from the cable assembly.

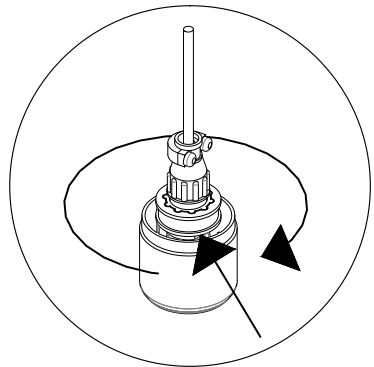

3. Replace the Transducer by rotating the locking ring. The transducer will only go on one way.

4. Reassemble transducer cage and tighten the four screws

HANDLE ASSEMBLY

1. Remove the two visible screws using a Philips head screwdriver

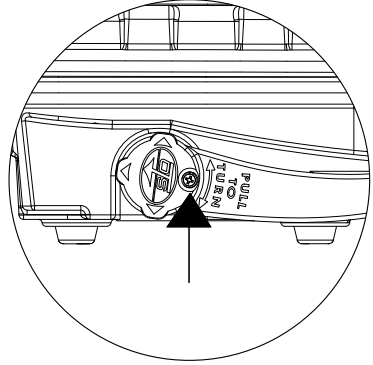

2. Pull the handle open and rotate the handle down two steps as shown

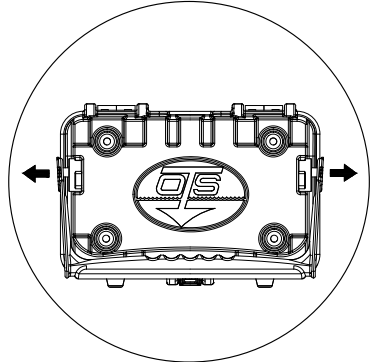

3. Remove the two screws that were revealed by rotating the handle.

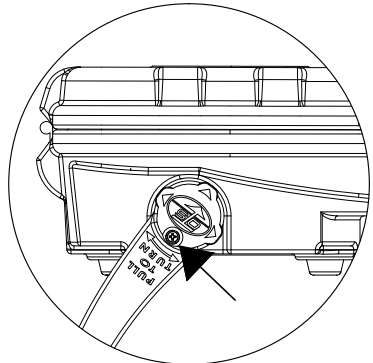

4. Pull the handle apart as you would to rotate it. The handle will now pull free from the unit.

5. Replace handle with new part by reversing these instructions.

TROUBLESHOOTING GUIDE

Issue	Step 1	Step 2
No power, when the Transducer is connected	-Connect 12 VDC external battery or 12 VDC power supply -Charge battery -Change Battery -Change Transducer cable	Contact OTS.
Squealing noise, when the Transducer is connected	Disconnect Transducer, wait for 10 seconds. Reconnect Transducer	Contact OTS.
No Transmit	-Change Handheld Microphone or Headset -Change Transducer	Contact OTS.
No Transmit and Speaker or Headset does not Mute	-Change Handheld Microphone or Headset	Contact OTS.
No sound through Speaker	-Connect Headset: If there is normal sound through headset, either bad speaker or bad PC board.	Contact OTS.
No sound through Headset	-Disconnect and use speaker. If sound is audible from the speaker, bad headset or bad PC board	Contact OTS.
Cannot change Channel	Contact OTS.	
Cannot Turn Squelch On / Off	Contact OTS.	
Cannot Turn Scrambler On / Off	Contact OTS.	
Scrambler LED turn off, but unit stuck on Scrambler mode	-Disconnect Transducer, wait for 10 seconds then reconnect Transducer to the unit. -Contact OTS.	
Scrambler LED turns on, but unit stuck on normal mode	- Disconnect Transducer, wait for 10 seconds then reconnect Transducer to the unit. -Contact OTS.	
Charger LED illuminates green, Disconnect Charger. but the unit power will not activate.	Battery is "dead". Replace the battery.	Contact OTS.
Charger LED doesn't turn green after 12 hours of charge.	Unplug charger from AC power. Connect transducer to power on the unit. Check unit for full Indicated charge.	Contact OTS.

UNDERSTANDING WIRELESS UNDERWATER COMMUNICATIONS

FACTORS THAT AFFECT WIRELESS COMMUNICATIONS

There are many factors that affect the propagation of sound in water. The net result is that communication in water can be affected by local conditions and the kind and depth of dive being conducted. The following sections explain some of the factors that can affect the operating range of underwater communication:

DISTANCE

The sound intensity from a source varies inversely with the distance from the source. As the sound passes through the water, some of the energy is converted to heat and some energy is scattered by fish, pilings, seaweed, bubbles, etc. In addition, both the surface and bottom may affect the sound intensity by either reflecting or diffusing sound waves. If the source is near the surface, there is a point beyond which sound is not received from the source. This point is said to be in a "Shadow Zone". The distance from the source to the shadow zone is determined by Thermoclines in the water.

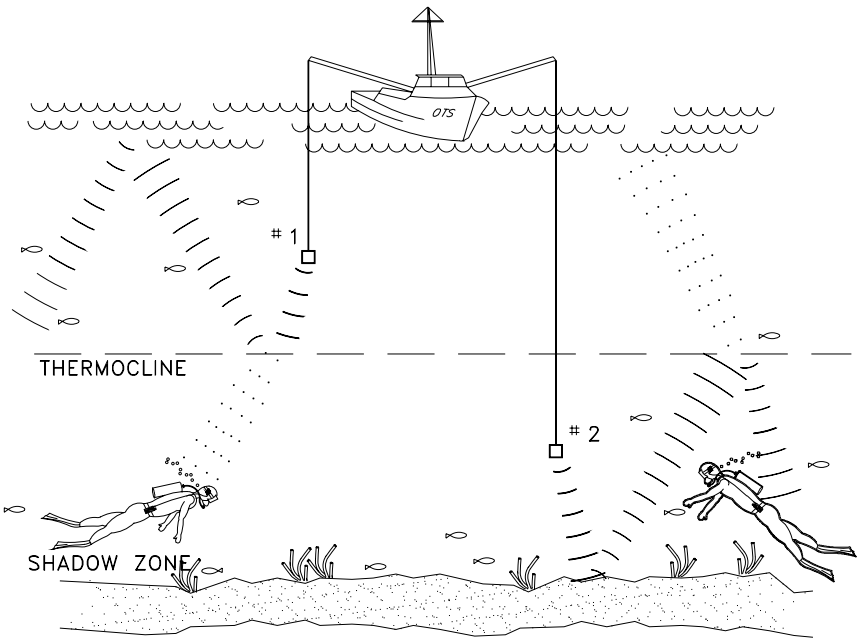

WATER TEMPERATURE

Variations in water temperature affect sound transmission most. In some areas of the ocean, the temperature changes at a fixed rate over large ranges of depth. If the temperature increases with depth, the velocity of sound increases and the sound waves will be refracted toward the surface. If, however, the temperature decreases with the depth, the velocity of sound decreases and the waves of sound are bent downward.

There are also areas in the sea where temperature changes rapidly over a small depth range called a thermocline. Thermoclines can produce a sharp bending of sound waves and may serve as reflecting surfaces. The velocity of sound transmission changes only about one percent for a temperature change of 10°F (5.6°C). However, the bending of the sound path has great effect over a distance of several hundred yards (meters).

If the temperature of the water decreases with depth at the rate of 1°F for each 30 feet (.56°C for every 9 meters), most of the sound energy originating at the source near the surface will travel along paths that are bent downward. Therefore, the sound energy may not reach a shallow detector positioned 1000 yards (914 meters) from the source but may reach a deeper detector position further from the source. Greater temperature variations can cause these paths to bend more sharply. The best method to deal with thermoclines is to bring the divers and/or transducers as close to each other as possible. If a diver enters a thermocline, the diver should report it to everyone (surface and divers) so they know the depth of the thermocline. All divers should stay within that depth, and the surface station should try to position the surface transducer below or above, whichever is the case.

WATER DENSITY

Water density is important for the propagation of the sound. Because the density of sea water varies with temperature, salt content, and static pressure, the effect on sound of each of these three factors is usually considered separately.

BACKGROUND NOISE

Marine organisms play an important role in underwater acoustics. They are important primarily because of the effect they have on sound transmission, but they often serve as sources of underwater noise as well. High background noise can interfere with good communications. Such background noise can be mitigated with the squelch function.

ZONES OF SILENCE

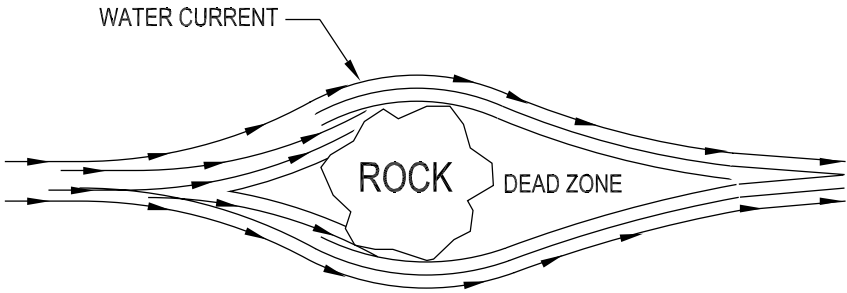

Large natural or man-made objects can block acoustical transmission under certain conditions, in much the same way that a rock blocks a fast-moving current of water. Close to the backside of the rock, in this example, the current is absent and the water seems still. A short distance away, the current is flowing again.

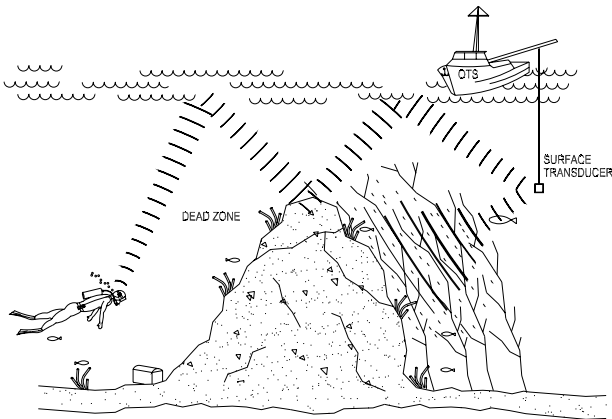

Similarly, acoustic energy in the water can be blocked if the transmitting source is close to a large object. On the backside of the blocking object, a "zone of silence" is formed in which reception of the transmitted signal is not possible. Divers can reduce "zones of silence" by moving away from, around, or above the blocking object until communication is re-established.

Under some conditions, when a diver's suit and body are directly between the transmitting Milcom 6000 Surface Station and the diver's radio, a small zone of silence may be created that prevents reception. This effect can become greater at longer ranges. The diver turning 45 degrees in any direction eliminates this zone of silence.

For more information on Wireless Communications, visit the Learning Center on our website at: WWW.OTSCOMM.COM

NOTES

NOTES

LIMITED WARRANTY

The POWERCOM SURFACE STATION (3000S & 5000S) & MILCOM SURFACE STATIONS are fully warranted against defects in materials and workmanship, including labor, for a period of one year from the time of purchase. Our obligation under this warranty is limited to the replacing of any part or parts which prove to our satisfaction to have been defective and which have not been misused or carelessly handled.

You must contact an official Ocean Technology Systems (OTS) Service Center or OTS directly to obtain service. If you would like to request an RMA #, please request one electronically by accessing the service section of our website. The complete unit and/or damaged part shall be returned to our factory, transportation charges prepaid. We reserve the right to decline responsibility where repairs have been made or attempted by any party other than an OTS service factory trained center or properly trained personnel.

In no event shall OTS be liable for consequential damages related to our product/s.

Warranty registration is required. Any parts requiring replacement due to excessive wear or damage are not covered in this offer. Customer will be notified of any additional charges for worn or damaged components. The customer is responsible for shipping charges to the factory. OTS will pay return shipping using UPS Ground service or equivalent for repairs covered by this warranty only. Any other shipping requirements are the responsibility of the customer.

Undersea Systems International, Inc.
dba
Ocean Technology Systems
3133 West Harvard St., Santa Ana, CA 92704 USA
Telephone: 714.754.7848 Fax: 714.966.1639
E-Mail: ots@otscomm.com
Web: www.otscomm.com

506295-001 Rev. A

© Copyright 2022 by Undersea Systems International, Inc., dba
Ocean Technology Systems. All rights reserved. Specifications subject to change without
prior notice.